

MODEL	RATED TORQUE @ STD. AIR GAP		BREAKAWAY TORQUE		MAX RPM
MDC 2	1.7 Nm	15 Lb-in	2.3 Nm	20 Lb-in	15,500

REVISIONS			
REV.	ECN.	DESCRIPTION	DATE

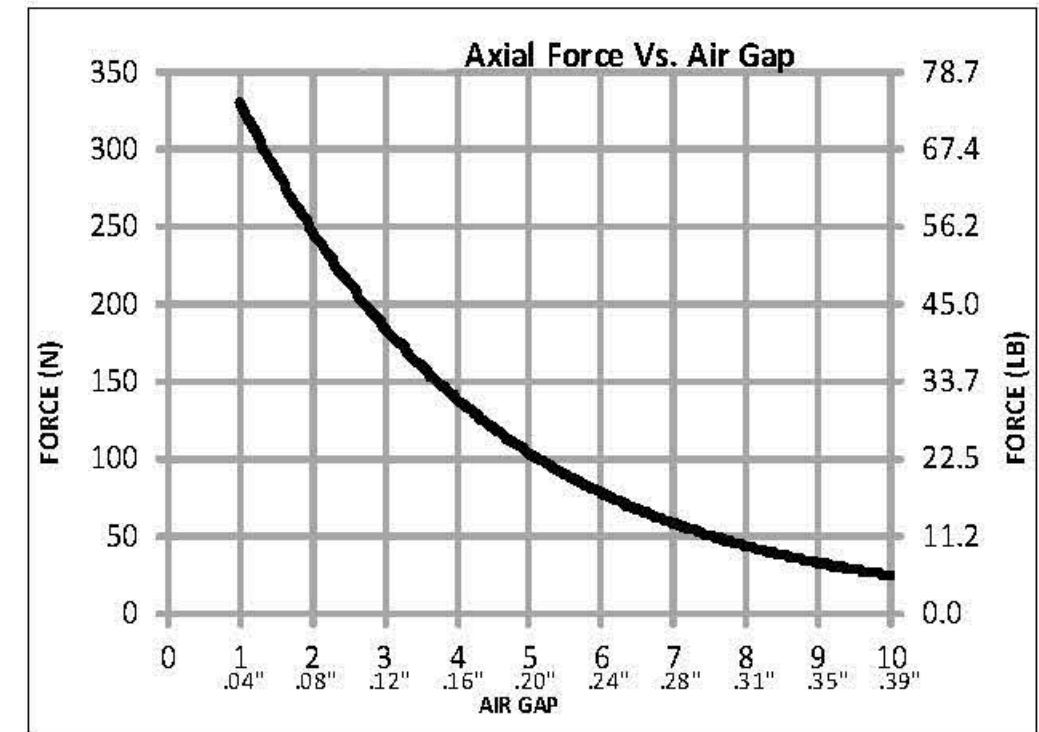
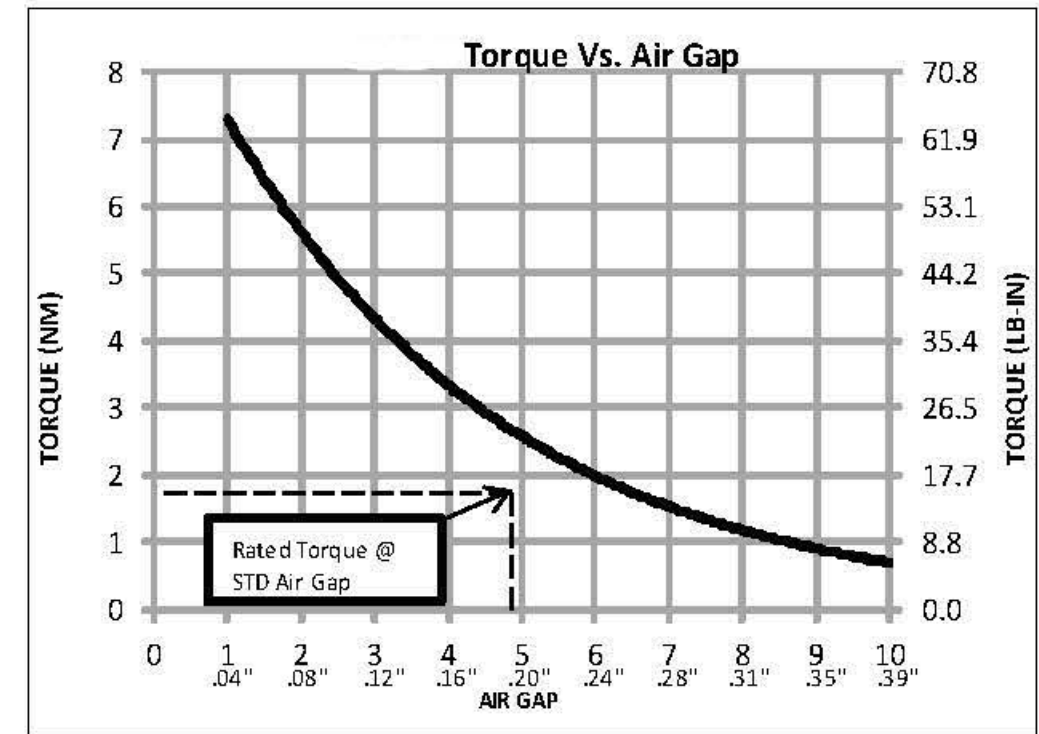
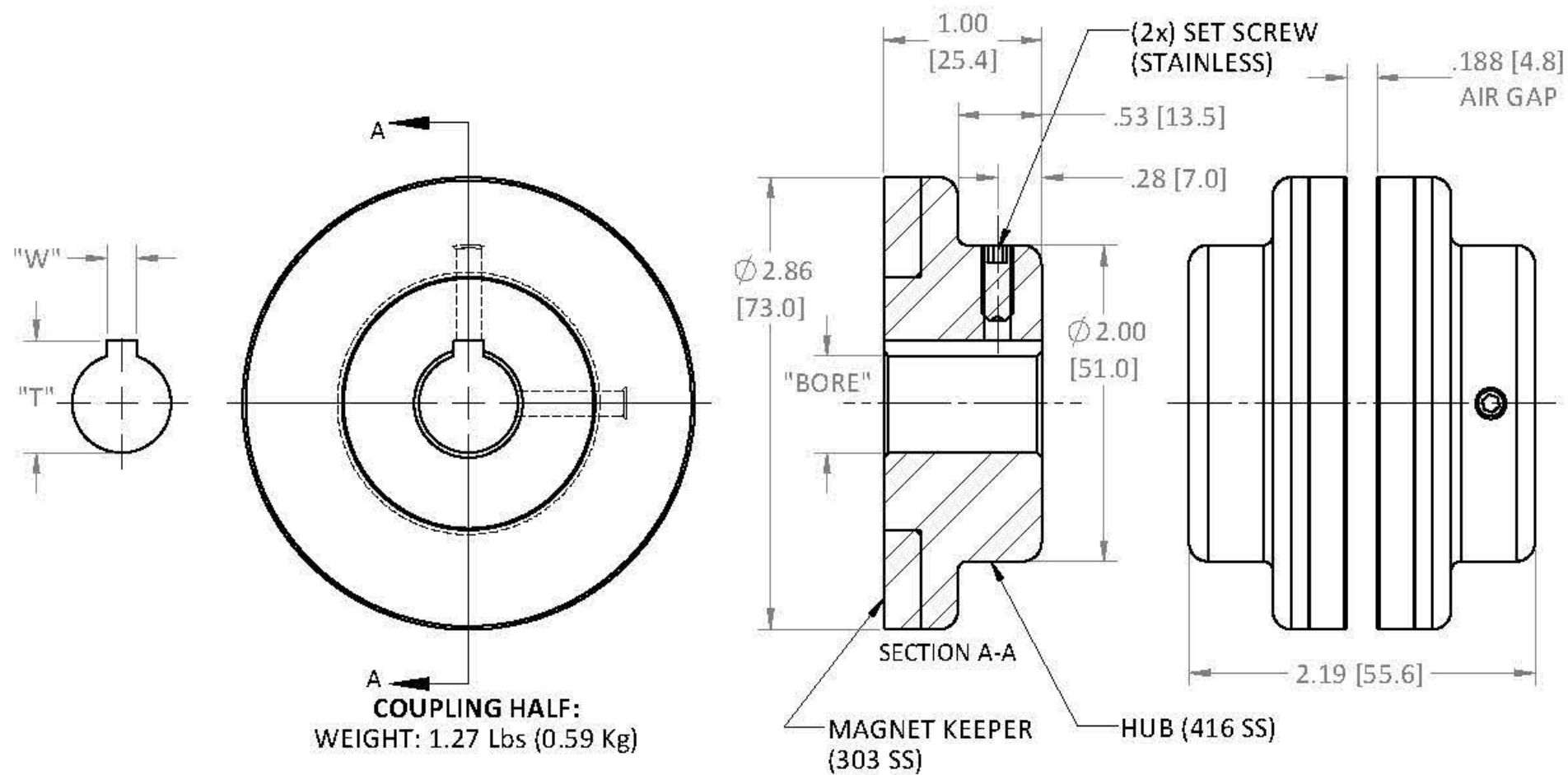

MODEL	BORE		W		T		SET SCREW (2x)
	mm <sup>H8</sup>	in <sup>±.001</sup>	mm <sup>±.05</sup>	in <sup>±.002</sup>	mm <sup>±.25</sup>	in <sup>±.010</sup>	
MDC 2							CUP POINT
	SOLID		-		-		-
	11.00	.433	4.000	.1574	12.80	.504	M5-0.8 X 12mm
	12.00	.472	4.000	.1574	13.80	.543	M5-0.8 X 12mm
	12.70	.500	3.175	.1250	14.22	.560	#10-32 X 1/2
	14.00	.551	5.000	.1969	16.30	.642	M5-0.8 X 12mm
	15.88	.625	4.763	.1875	18.01	.709	#10-32 X 1/2
	18.00	.709	6.00	.2362	20.80	.819	M5-0.8 X 12mm
	19.00	.748	6.000	.2362	21.80	.858	M5-0.8 X 12mm
	19.05	.750	4.763	.1875	21.26	.837	#10-32 X 1/2
	22.23	.875	4.763	.1875	24.49	.964	#10-32 X 1/2
	25.40	1.000	6.350	.2500	28.30	1.114	1/4-20 X 1/2

OTHER SIZES AVAILABLE; SPECIFY BOTH BORE AND KEYWAY

USED ON	SCALE 1:1	MATERIAL SEE PRT DWG	DESCRIPTION  <b>Cut Sheet</b>
UNLESS OTHERWISE SPECIFIED:		FINISH SEE PRT DWG	
ALL DIMENSIONS ARE IN INCHES TOLERANCES: DECIMAL: JX ± .01 - JXX ± .005 ANGULAR: ± 1° GEN. CONCENTRICITY: .001 T.I.R. MACH. FILLETS: .010 R MACH. EDGES: .015 R OR CHMF. UNSPECIFIED RADII: .015 R IN MICROINCHES RMS 32 GEOMETRIC: TO MIL-STD. 8 REMOVE ALL BURRS & SHARP EDGES		DRAWN AMD 6/6/14	
		CHECKED	
		SIZE: B	DWG. NO.
			REV.